



MVS45L X

TROLLEY VACUUM - SEALING BAR 450 MM
VACUUM MACHINE WITH CARRIAGE



DESCRIPTION

Maximum simplicity of setting and use, in front of the availability of many technological content and functions of high quality. These are the main features of **MVS X chamber vacuum sealers**, made with the help of professional chefs who have been able to enrich the equipment with new functions of the latest generation, cut out on the specific needs of professional operators.

These **vacuum packaging machines** allow to operate up to 10 different programs, customised to the main packaging requirements. The control panel with tactile controls is hermetically sealed on the front of the bodywork, so as to prevent any fluid filtration on the board.

Other features include:

- Special message that warns of the need for oil change
- Electronic sensor which, importing data directly from the card, is able to calculate the vacuum realized



in the Chamber

- Possibility of setting the machine to the vacuum on the atmospheric pressure conditions at the different altitudes

TECHNICAL FEATURES

Electrical power supply		V	120/230
Phase	ph	1	
Dimensions of sealing bars	mm	MVS45L XP FRONT B. 450 (no. 1 front) MVS45L XP 2 SIDE B. 450 (no. 2 side bars)	
Packaging cycle (Vacuum 20%)	sec.	Vacuum =24 - Air re-immission =8	
Vacuum pump	mc/h	20	
Work surface height	mm	889	
Machine dimensions with the lid open	mm	546x676x h.1200	
Machine dimensions with the lid closed	mm	546x676x h.1012	
Machine weight (Net/Gross)	kg	104/129	
Available chamber dimensions (Tank+lid)	mm	MVS45L XP FRONT B. 466x405.5x h.226 MVS45L XP 2 SIDE B. 351x466x h.226	

minipack@-torre shall not be held liable for typos or printing errors in this catalogue. It also reserves the right to make changes to the specified features without prior notice. All trademarks are property of their respective owners and are hereby acknowledged.

TECHNICAL DRAWING

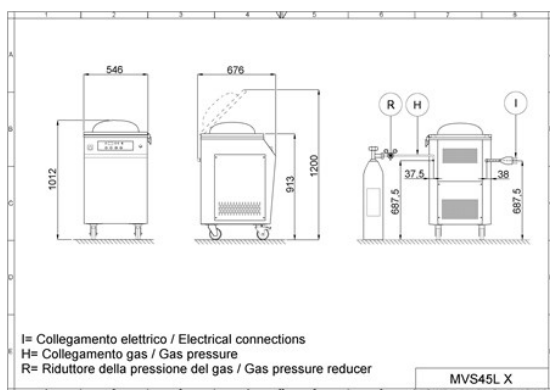

minipack@-torre S.p.A.

Sede legale - Via Provinciale, 54 - 24044 DALMINE (BG) Italy

P.IVA - C.F.: 01633550163 - Capitale sociale 619.200,00 i.v. - Reg. Imprese di Bergamo 01633550163 - REA n. 224151



TECHNICAL FEATURES

- Stainless steel (AISI 304)
- Vacuum cycle with stop
- Bag scrap cutting device
- Quick-coupling aluminium sealing bar
- Clear plastic lid suitable for use with food
- Volumetric vacuum sensor
- PE-HD filling tables
- 10 customisable programs
- Self-calibration
- Sealing bar overload safety device
- Oil and assistance warning light
- CE/ETL/NSF certification.

VERSIONS

MVS 45L X FRONT B. (MVS 45L X front bar)

MVS 45L X 2 SIDE BARS (MVS 45L X 2 side bars)